



fischertechnik  
Radio-Control-  
System

Fernlenk-Set/Radantrieb und Servo  
Remote steering and driving unit  
Elément de direction plus élément d'entraînement  
Besturingsset, wielaandrijving + servo  
Juego con mando a distancia y aparato reductor de  
movimiento asistido  
Set con sterzo telecomandato e regolazione del  
movimento  
Set med fjärmanövrering/hjuldrift och servo  
無線操縦 - セット / 車輪伝導装置とサーボ



Steuerpult/Schaltplan	4	Einbau in den Hydraulikkipper	16
Control panel/wiring scheme	4	Installation in hydraulic	
Pupitre de commande/schéma		tipping lorry	16
de connexion	4	Montage dans les camions	
Stuurpaneel/schakelschema	4	basculants hydrauliques	16
Pupitre de mando/esquema		Montage in de hydraulische	
de distribución	4	kipwagen	16
Quadro di comando a leggìo/ schema	4	Incorporación en el volcador	
Manöverpanel/kopplingsschema	4	hidráulico	16
コントロールテスク / 配線図	4	Montaggio nei ribaltabili	
		idraulici	16
		Inmontering i hydraulisk	
		tippare	16
		液圧(ハイドロ)制御ダンパーへの組込み	16

Modellfahrzeuge	6	Sonstige Anwendungen	22
Model vehicles	6	Other applications	22
Véhicules modèles	6	Autres utilisations	22
Modelvoertuigen schakelschema	6	Overige gebruiksmogelijk-	
Vehículo de modelo	6	heden	22
Automodelli	6	Otras aplicaciones	22
Modellbilar	6	Altre applicazioni	22
モデル車輛	6	Övriga användningsområden	22
		その他の用途	22

Einbau in den Abschleppwagen	8
Installation in salvage lorry	8
Montage dans les dépanneuses	8
Montage in de takelwagen	8
Incorporación en el coche-grúa	8
Montaggio nei carri attrezzi	8
Inmontering i bärgningsbil	8
レッカー車への組込み	8

Steckermontage  
Plug connection  
Montage des fiches  
Stekkermontage  
Montaje del enchufe  
Montaggio spine  
Kontaktmontering  
プラグ取付け

schwarzes Kabel  
black cable  
câble noir  
zwarte kabel  
cable negro  
cavo nero  
svart kabel  
黒ケーブル

rot-grünes Kabel  
red-green cable  
câble rouge-vert  
rood-groene kabel  
cable rojo verde  
cavo rosso-verde  
röd-grön kabel  
赤・緑ケーブル

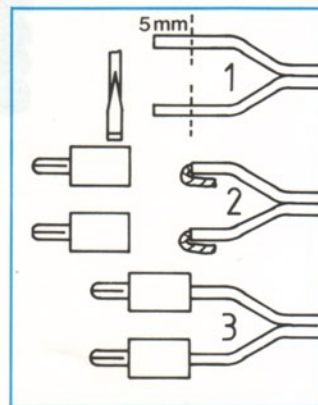
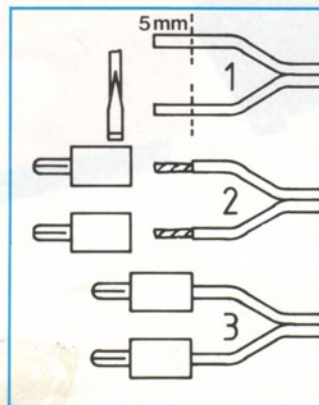

Antriebseinheit mit Differential  
Drive unit with differential gearing  
Unité de commande avec différentielle  
Aandrijfunit met differentieel  
Unidad propulsora con diferencial  
Unità di azionamento con differenziale  
Drivenhet med differential  
デフ付き駆動ユニット

Lenkeinheit/Servo  
Steering unit/servo  
Unité de direction/Servo  
Stuurunit/bekrachtiging  
Unidad de dirección/Servo  
Unità di guida/servosterzo  
Styrenhet/servo  
かじ取りユニット / サーボ

Download von [www.ft-fanarchiv.de](http://www.ft-fanarchiv.de)  
gescannt von Peter Remm

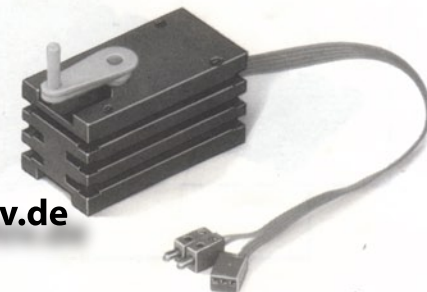

Ladebuchse  
Charging socket  
Boîte douille de  
chargement  
Laadbus  
Borne de carga  
Presa di alimentazione  
Laddningsdosa  
充電用ソケット

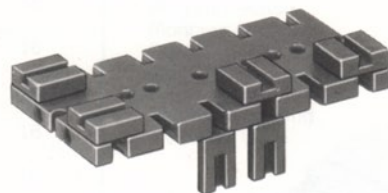
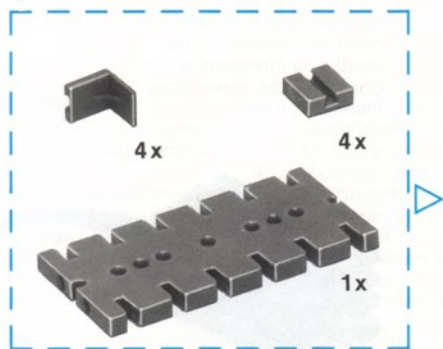
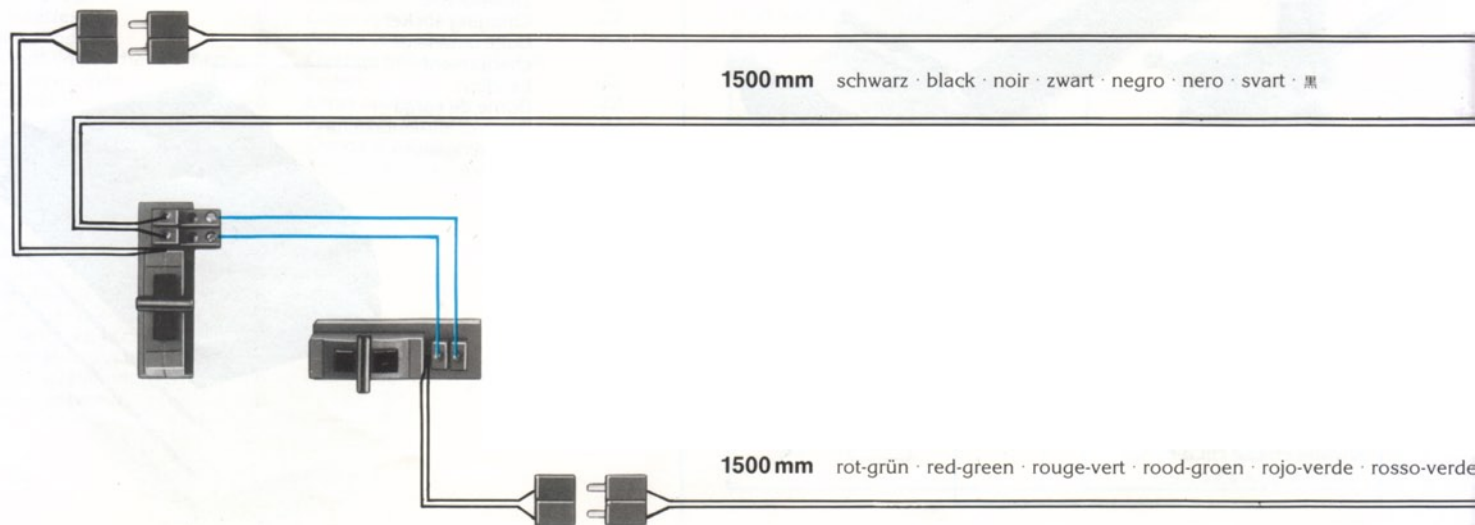
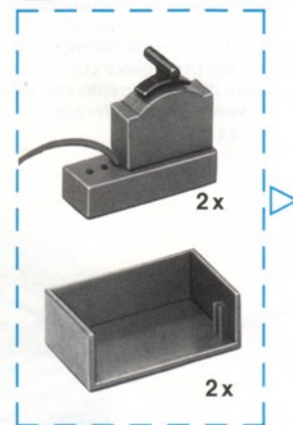

Nur NiCd-Akku verwenden!  
Use NiCd-accumulator only!  
N'utiliser que des batteries NiCd!  
Uitsluitend nicd-accu gebruiken!  
Utilizar solamente acumuladores con NiCd!  
Utilizzare soltanto accumulatori al  
cadmio-nichel!  
Använd endast NiCd-batteri!  
ニッカド電池のみ使用のこと！

**1****2**

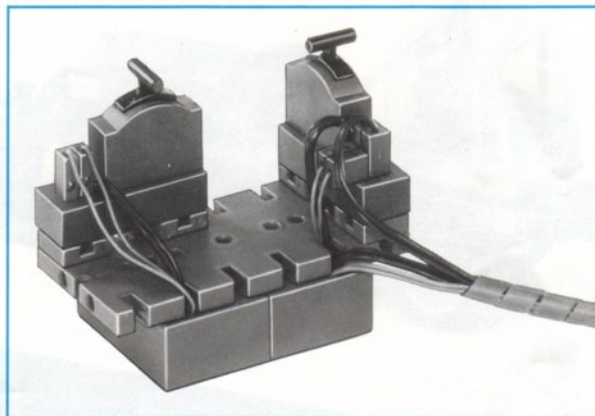
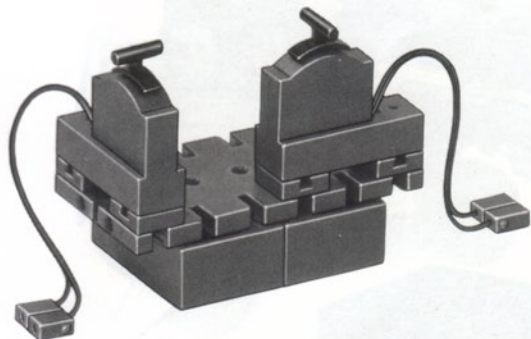

Steckerbuchse nur für Fernsteuerung  
 Socket for remote control only  
 Fiches femelles seulement pour la télécommande  
 Stekkerbus uitsluitend voor afstandbesturing  
 Borne de enchufe solo para control a distancia  
 Presa solo per comando a distanza  
 Kontakturtag för fjärrstyrning  
 リモコン用のみのプラグソケット

・röd-grön · 赤 · 緑

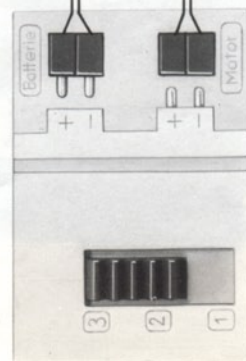
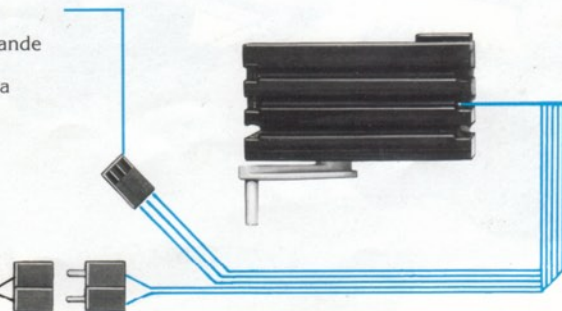



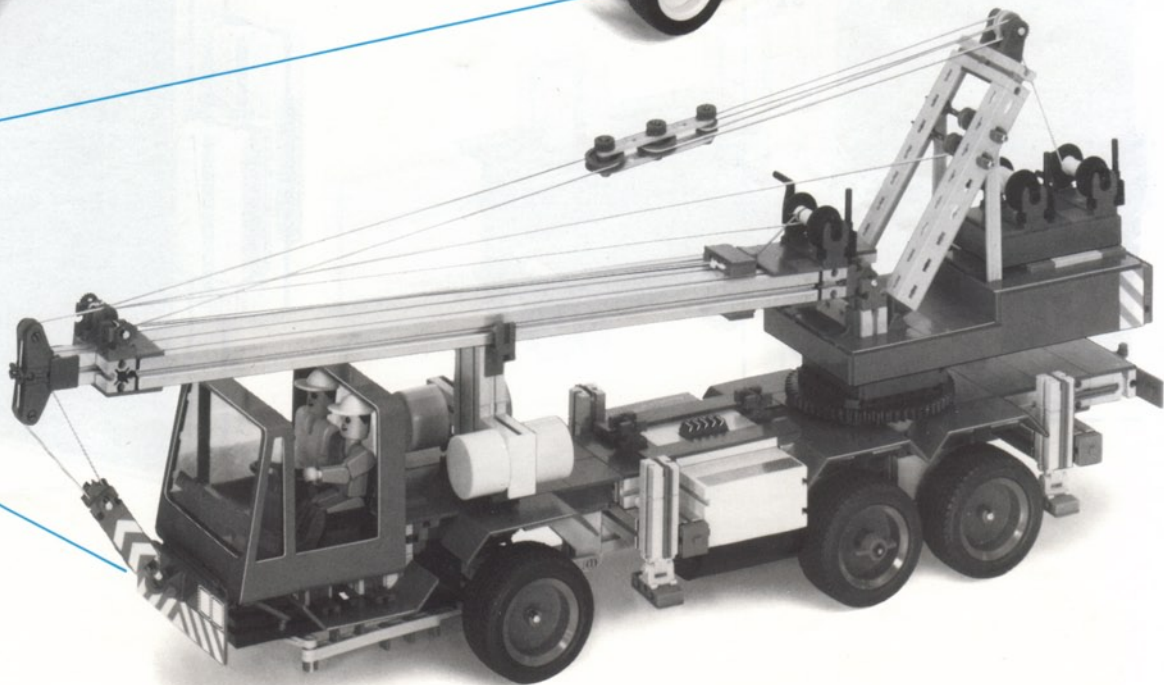

- 1** Einbau in den Abschleppwagen  
Installation in salvage lorry  
Montage dans les dépanneuses  
Montage in de takelwagen  
Incorporación en el coche-grúa  
Montaggio nei carri attrezzi  
Inmontering i bärgningsbil  
レッカー車への組込み

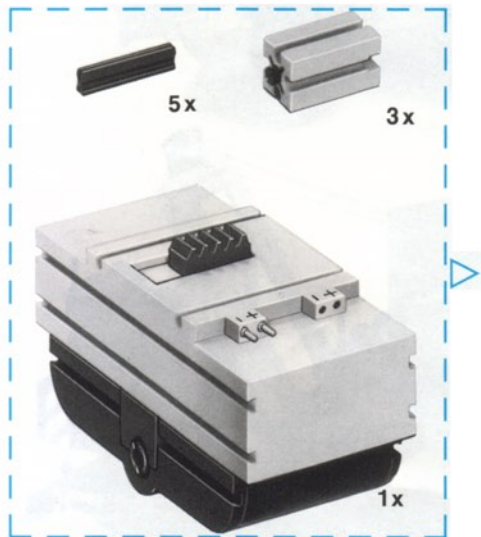



# 2

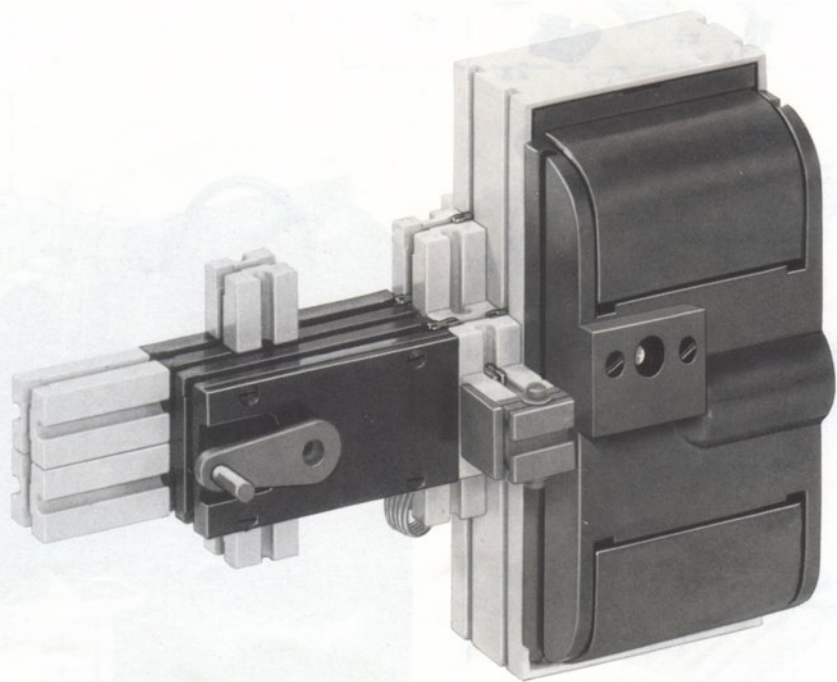
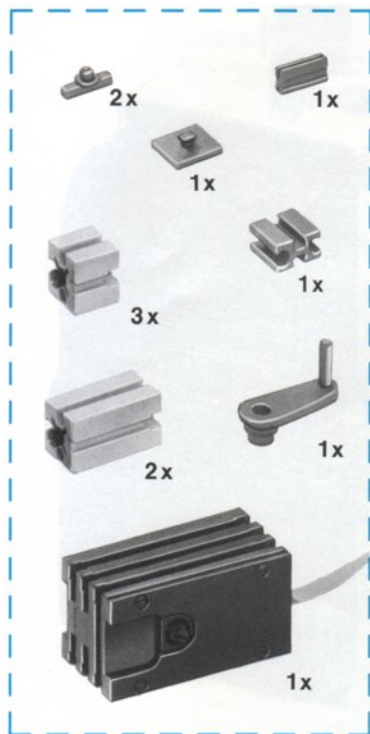

3

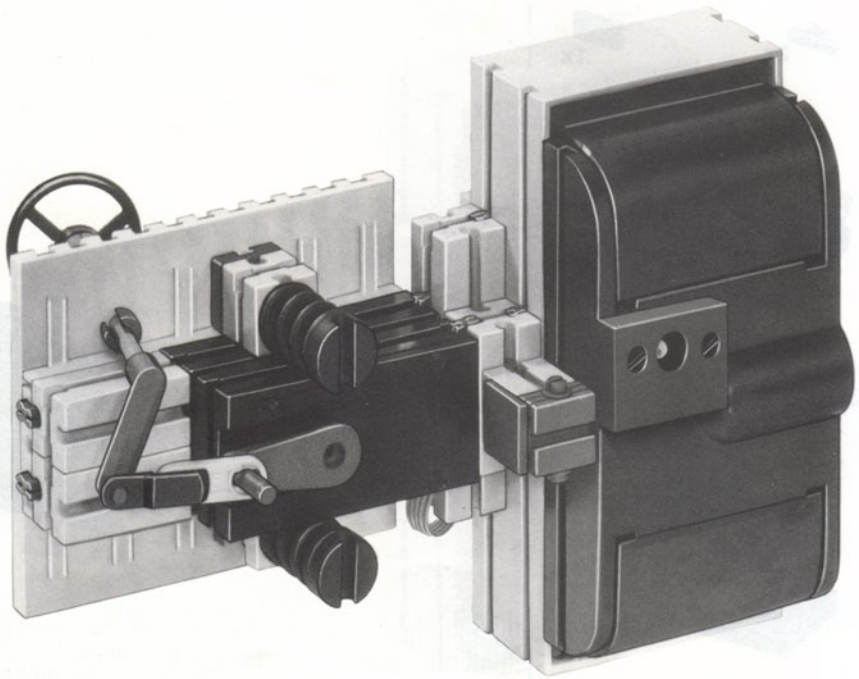

4

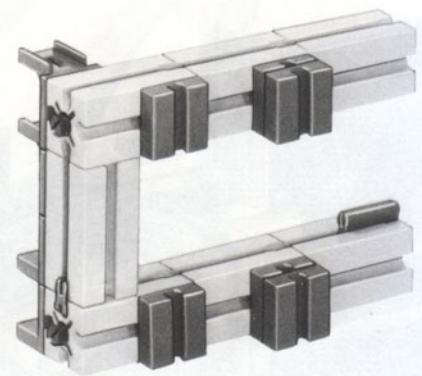
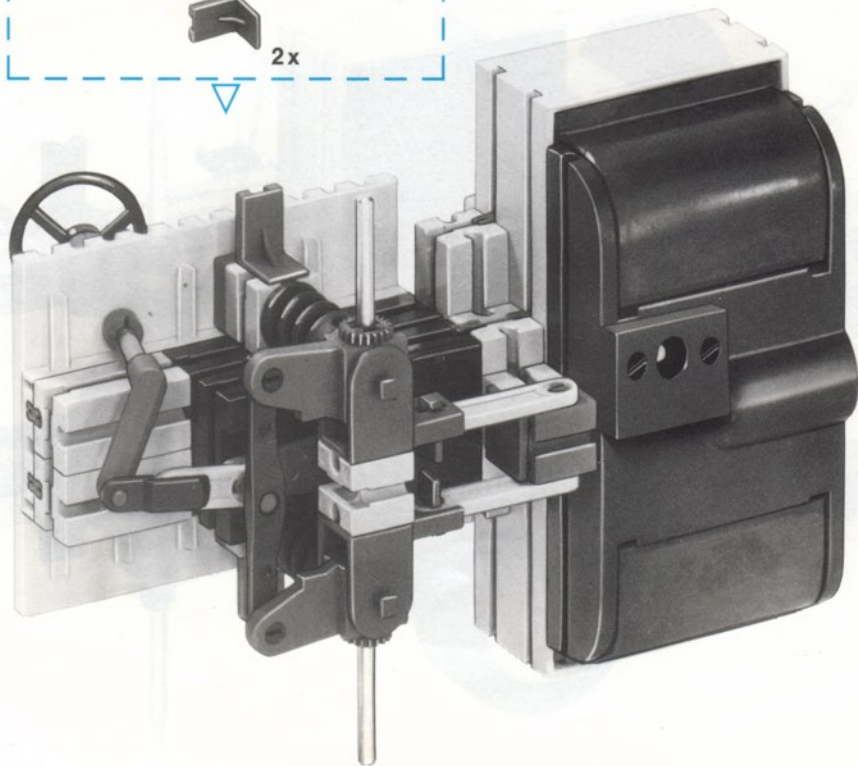
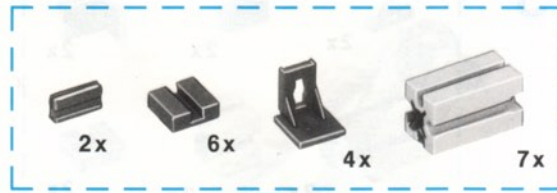
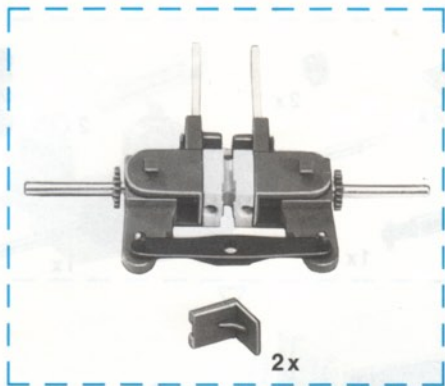

5

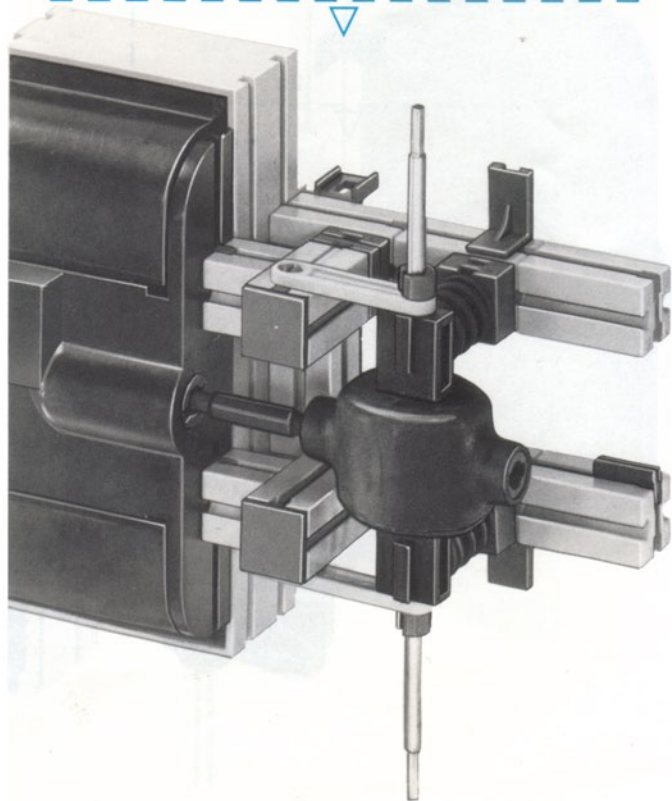
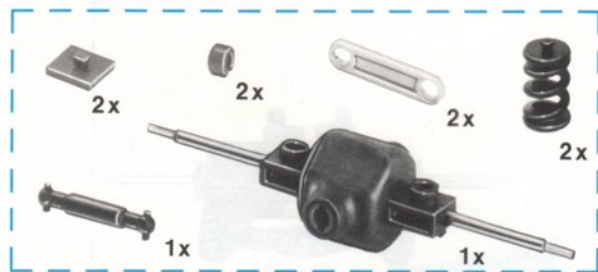
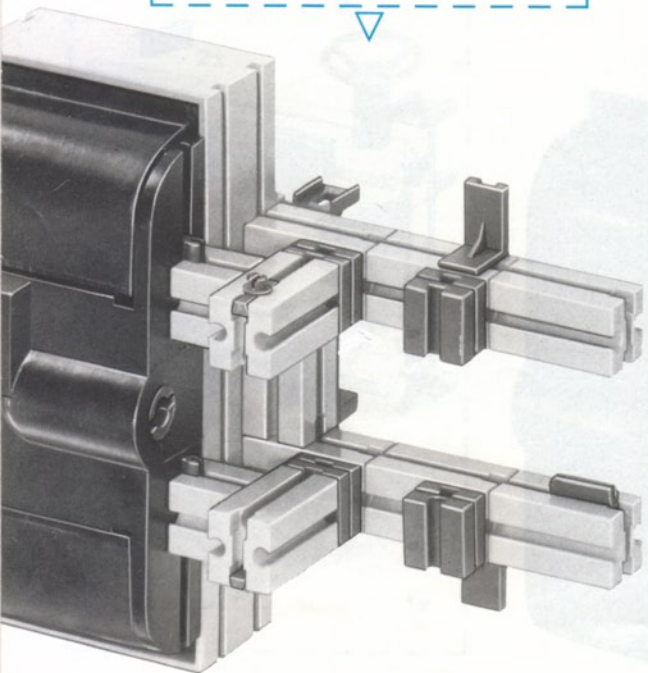
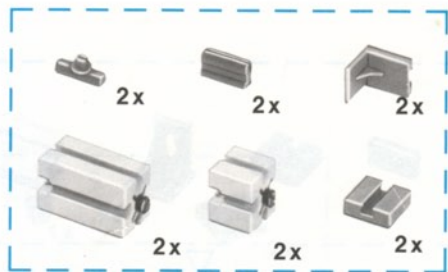





Abschleppwagen, ferngesteuert  
Salvage lorry, remote-controlled  
Dépanneuses, télécommandées  
Takelwagen, afstandbesturing  
Choche-grúa, controlado a distancia  
Carro attrezzi, comandato a distanza  
Bärgningsbil, fjärrstyrd  
レッカー車、リモコンに依る。



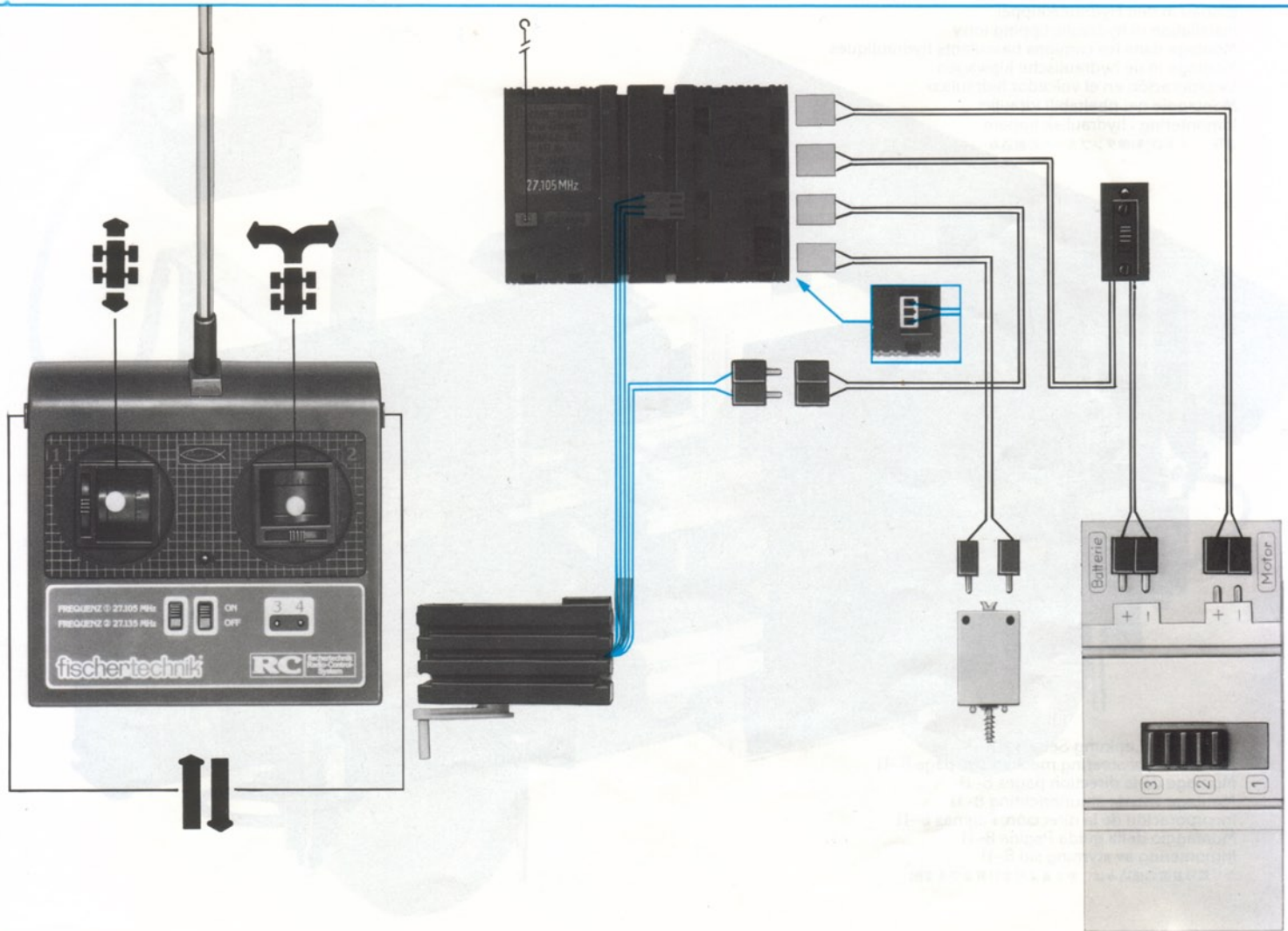

Einbau in den Hydraulikkipper  
Installation in hydraulic tipping lorry  
Montage dans les camions basculants hydrauliques  
Montage in de hydraulische kipwagen  
Incorporación en el volcador hidráulico  
Montaggio nei ribaltabili idraulici  
Inmontering i hydraulisk tippare  
液圧(ハイドロ)制御ダンパーへの組込み

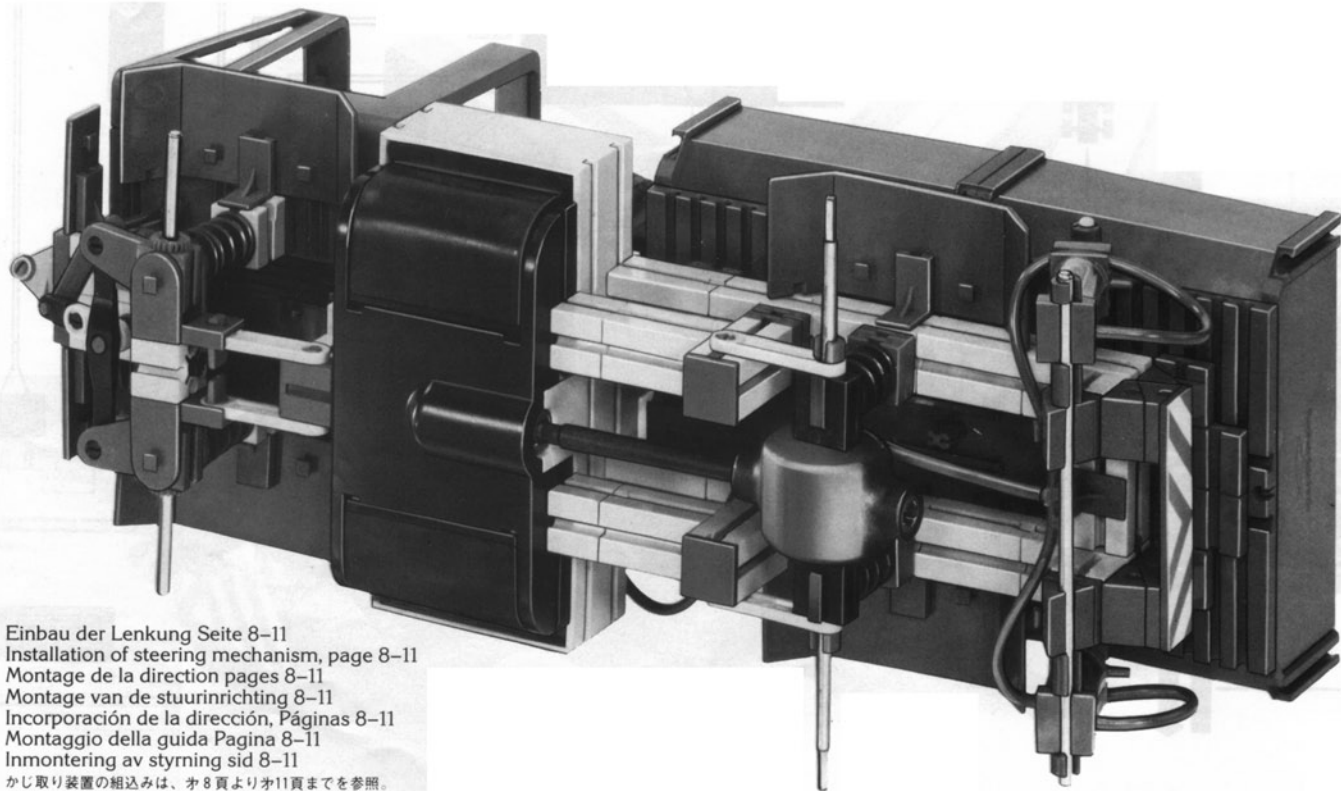

Einbau der Lenkung Seite 8-11  
Installation of steering mechanism, page 8-11  
Montage de la direction pages 8-11  
Montage van de stuurinrichting 8-11  
Incorporación de la dirección, Páginas 8-11  
Montaggio della guida Pagina 8-11  
Inmontering av styrning sid 8-11  
かじ取り装置の組込みは、オ 8 頁よりオ11頁までを参照。







3

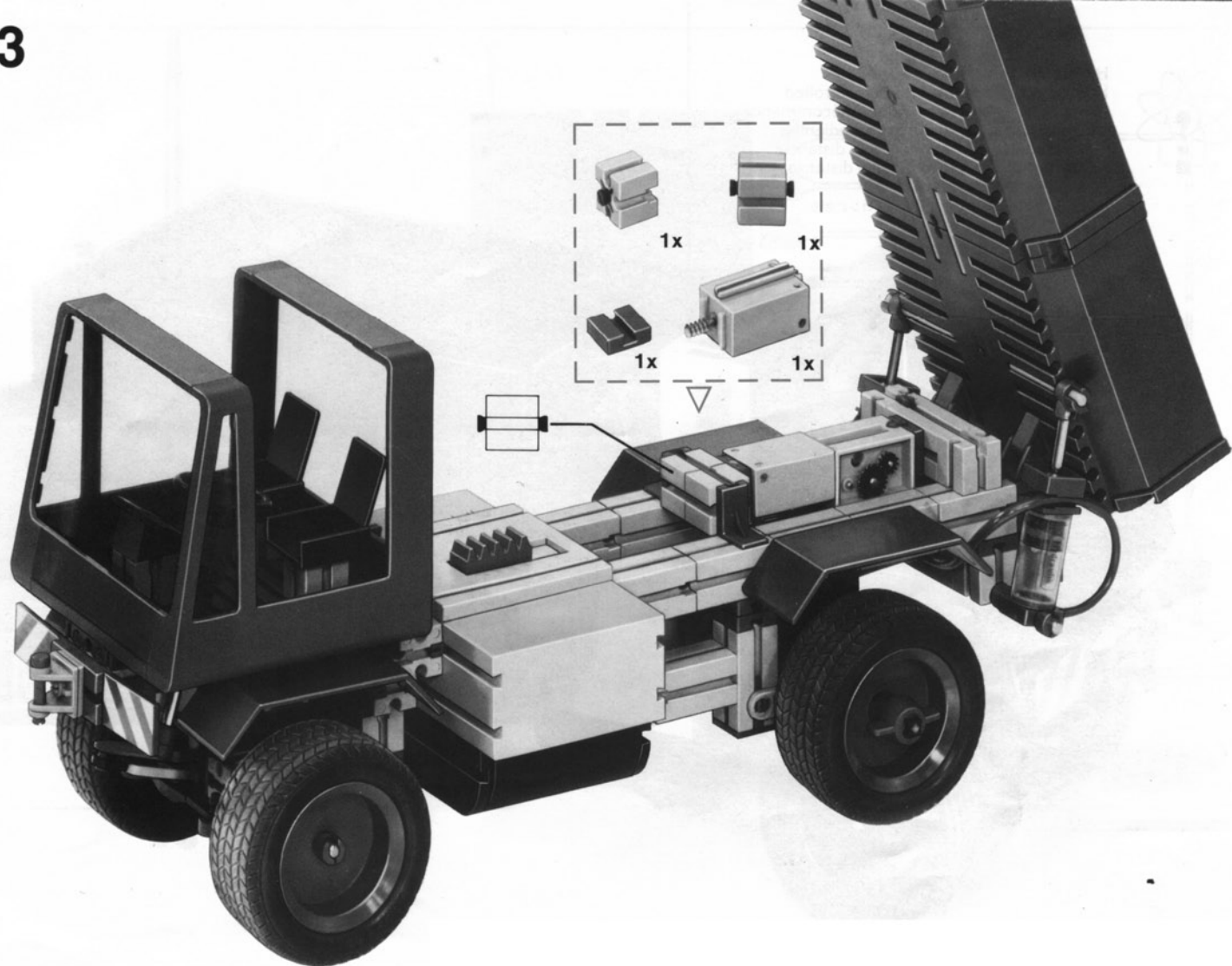



Hydraulikkipper, ferngesteuert  
Hydraulic tipping lorry, remote-controlled  
Camion basculant hydraulique, télécommandé  
Hydraulische kipwagen, afstandbediening  
Volcador hidráulico, controlado a distancia  
Ribaltabili idraulici, comandati a distanza  
Hydraulisk tippare, fjærrstyrd  
液圧 (ハイドロ) 制御ダンプカー、リモコンに依る。



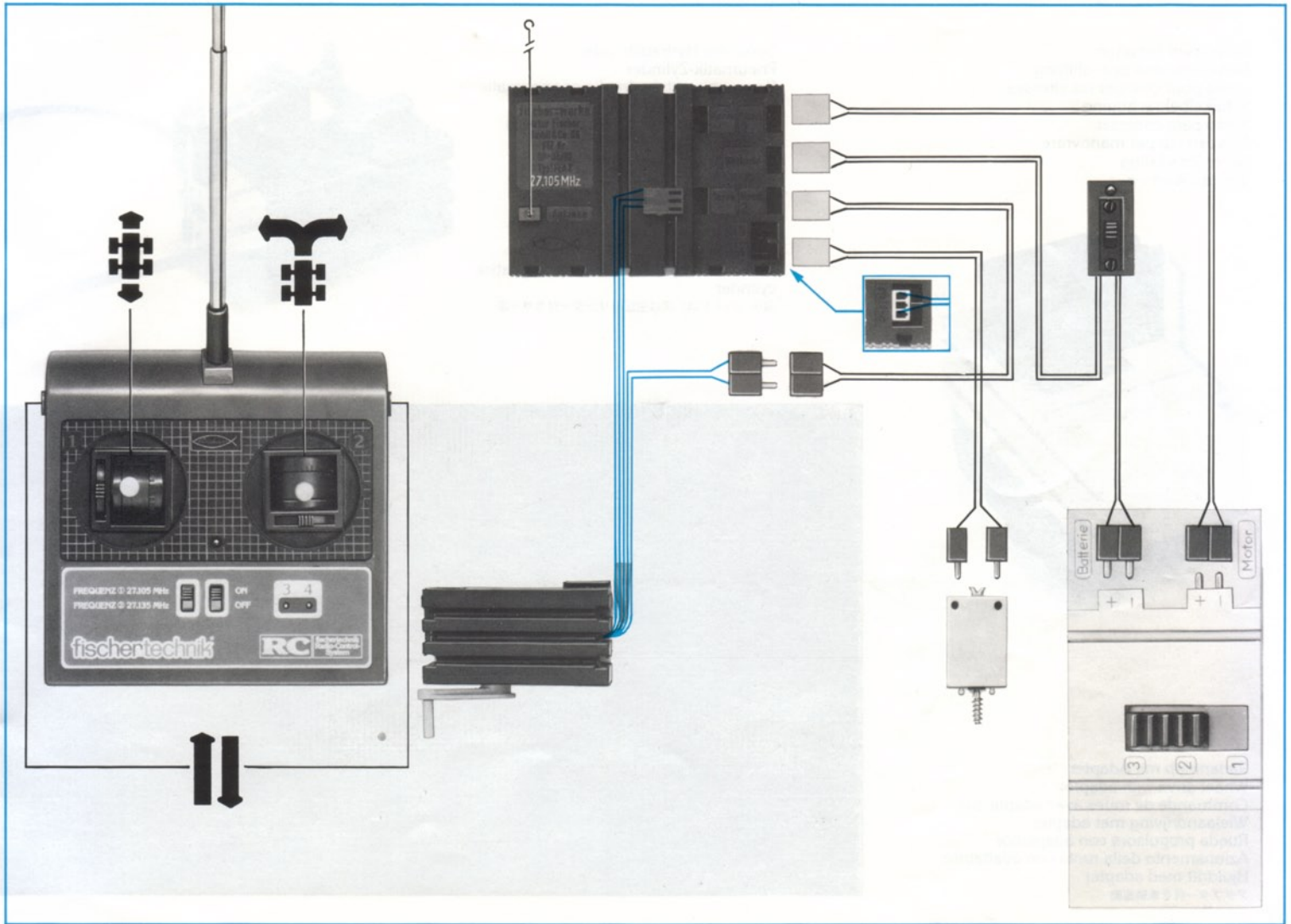

Servo zum Schalten  
 Servo-actuated gear-shifting  
 Servo pour changer les vitesses  
 Schakelbekrachtiging  
 Servo para conectar  
 Servosterzo per manovrare  
 Servo för växling  
 ギヤ切換え用のサーボ

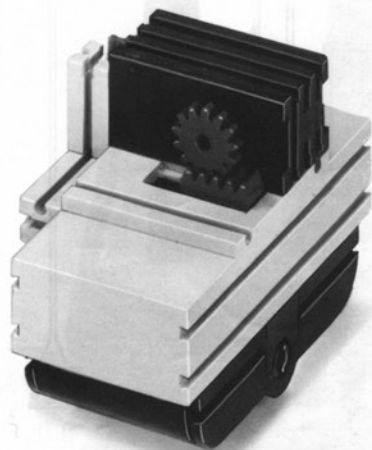

Servo mit Hydraulik- oder  
 Pneumatik-Zylinder  
 Servo-unit with hydraulic or pneumatic  
 cylinder  
 Servo avec cylindre hydraulique ou  
 pneumatique  
 Bekrachtiging met hydraulische of  
 pneumatische cilinder  
 Servo con cilindro hidráulico  
 o pneumático  
 Servosterzo con cilindro idraulico  
 o pneumatico  
 Servo med hydraulisk eller pneumatisk  
 cylinder

液圧 (ハイドロ) 又は空圧シリンダー付きサーボ

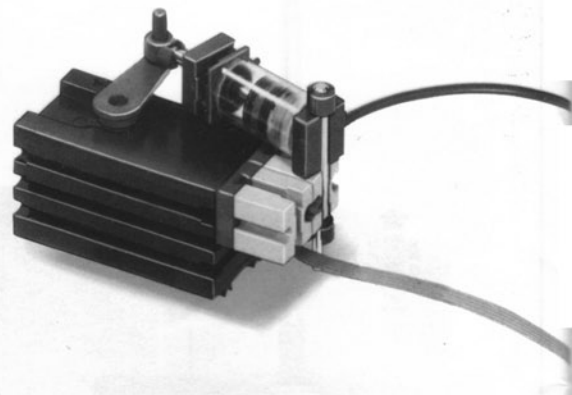

Radantrieb mit Adapter  
 Wheel drive with adaptor  
 Commande de roues avec adaptateur  
 Wiel aandrijving met adapter  
 Rueda propulsora con adaptador  
 Azionamento della ruota con adattatore  
 Hjuldrift med adapter  
 アダプター付き車輪駆動

